

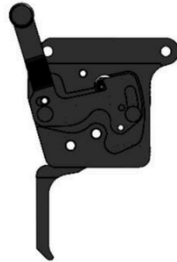

JARD Match Trigger System for 700 Clone Actions

Operator's Instruction Manual



3149 Nest Ave. – Sheldon, IA 51201
Phone: +1 (720) 446-8791
Email: Sales@jartriggers.com <https://jartriggers.com>

⚠ WARNING

This firearm is intended for use only by experienced competitive shooters and professionals. You must take responsibility for your own actions. We will not be responsible for any loss, injury, or death resulting from the use or misuse of this product.

The handling and use of firearms bears with a certain unavoidable risks, like sky diving and rock climbing. If you are not willing to accept responsibility for your own actions, guns are not for you.

The use of any custom parts or modifications may void any warranty from the manufacturer of your firearm.

Returns will not be accepted on any parts that have been modified.

If you do not have a thorough understanding of this trigger and the purpose and function of all the parts, do not attempt to install this system. Have it installed by an experienced gunsmith.

Installation

1. Visually check chamber to verify that the rifle is unloaded.
2. Remove the bolt from the receiver and the receiver from the stock.
3. Using a punch, remove the factory trigger housing from the receiver.
4. Install the JARD trigger into the receiver, reinstalling the bolt stop lever at this time.

Tips:

- a. Place the tapered end into the hole first.
 - b. Typically, it is easier to install the front pin first.
5. Make sure the trigger and sear pivot easily and do not bind.
 6. Place the bolt back into the receiver and make sure the bolt is cocked.
 7. Perform function and safety checks.

YOUR JARD TRIGGER SYSTEM COMES SET FROM THE FACTORY, NO ADJUSTMENT NEEDED.

If you must make adjustments, follow these instructions carefully. Only adjust the trigger if you fully understand the adjustment process. Adjustments done incorrectly can make your firearm unsafe!

1. Visually check chamber to verify that the rifle is unloaded.
2. **Sear Engagement** - With the bolt cocked and the safety off, turn the sear screw (8A) clockwise with a 1/16" hex key until the sear is released. Next, turn the screw back counter clockwise until a safe amount of sear engagement is achieved. (Approximately 1/3 turn)
3. **Over-travel** - With the action cocked, turn the over-travel screw (8B) clockwise with a 1/16" hex key to the point where pulling the trigger will not release the sear. Next, while pulling back on the trigger, turn the screw counter clockwise slowly until the sear is released. It should then be turned slightly further so there is clearance between the sear and trigger when the trigger is pulled. If there is insufficient clearance, the sear may not always be released cleanly when pulling the trigger.
4. Check the functioning of the trigger by slamming the bolt home (closing it sharply) several times. If the sear is released during this, then sear engagement must be increased and/or the weight of pull increased.
5. **Safety** - Adjust the offset safety screw (12) with 1/16" hex key so that there is NO trigger movement when the safety is on and the bolt is cocked. (Note: There must be sufficient sear engagement to allow reliable safety function.)
6. **Pull Weight** - May be adjusted slightly by adjusting the spring tension screw (9) with a 5/64" hex key. Turn the screw counterclockwise to lighten or clockwise to increase the pull weight.
7. If any screws turn easily with no resistance, remove them completely, clean, and apply blue thread locker. Allow thread locker to dry 24 hours before using the firearm.
8. Install the receiver back in the stock and perform safety and function checks.

JARD Match Trigger System for 700 Clone Actions Parts Breakdown List

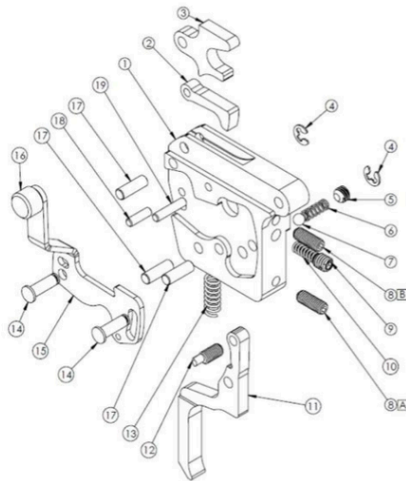

ITEM NO.	PART NO.	DESCRIPTION	QTY.
1	5791	Trigger Housing	1
2	5797	Lower Sear	1
3	5798	Upper Sear	1
4	1254	E-Clip	2
5	2952	Safety Spring Screw	1
6	1058	Spring	1
7	1163	.125 Ball	1
8	1148	Sear Adj. (A) / Overtravel Adj. (B)	2
9	5620	Pull Spring Adj. Screw	1
10	1058 1061 1062	Trigger Spring 4oz - 7oz 8oz - 14oz 15oz - 24oz	1
11	5795 5796	Trigger Straight Curved	1
12	1444	Safety Screw	1
13	1115	Spring	1
14	3537	Retaining Pin	2
15	5793	Safety	1
16	1231	Knurled Safety Knob	1
17	1238	Dowel Pin	3
18	1352	Dowel Pin	1
19	3069	Dowel Pin	1

JARD

3149 Nest Ave. - Sheldon, IA 51201
Phone: 720-446-8791 - Email: sales@jardtriggers.com